

ANALOG PERIPHERALS

- **12-bit ADC**
 - ±1LSB INL
 - Programmable Throughput up to 100ksps
 - 8 External Inputs; Programmable as Single-Ended or Differential
 - Programmable Amplifier Gain: 16, 8, 4, 2, 1, 0.5
 - Data Dependent Windowed Interrupt Generator
 - Built-in Temperature Sensor ($\pm 3^{\circ}\text{C}$)
- **8-bit ADC**
 - Programmable Throughput up to 500ksps
 - 8 External Inputs
 - Programmable Amplifier Gain: 4, 2, 1, 0.5
- **Two 12-bit DACs**
 - Can Synchronize Outputs to Timers for Jitter-Free Waveform Generation
- **Two Comparators**
- **Internal Voltage Reference**
- **Precision VDD Monitor/Brown-out Detector**

ON-CHIP JTAG DEBUG & BOUNDARY SCAN

- On-Chip Debug Circuitry Facilitates Full Speed, Non-Intrusive In-System Debug (No Emulator Required!)
- Provides Breakpoints, Single Stepping, Watchpoints, Stack Monitor
- Inspect/Modify Memory and Registers
- Superior Performance to Emulation Systems Using ICE-Chips, Target Pods, and Sockets
- IEEE1149.1 Compliant Boundary Scan
- Low Cost, **Complete** Development Kit: \$129

HIGH SPEED 8051 μC CORE

- Pipe-lined Instruction Architecture; Executes 70% of Instructions in 1 or 2 System Clocks
- Up to 25MIPS Throughput with 25MHz System Clock
- 22 Vectored Interrupt Sources

MEMORY

- 4352 Bytes Internal Data RAM (256 + 4k)
- 64k Bytes In-System Programmable FLASH Program Memory
- External Parallel Data Memory Interface – up to 5Mbytes/sec

DIGITAL PERIPHERALS

- 32 Port I/O; All are 5V tolerant
- Hardware SMBus™ (I2C™ Compatible), SPI™, and **Two** UART Serial Ports Available Concurrently
- Programmable 16-bit Counter/Timer Array with 5 Capture/Compare Modules
- 5 General Purpose 16-bit Counter/Timers
- Dedicated Watch-Dog Timer; Bi-directional Reset

CLOCK SOURCES

- Internal Programmable Oscillator: 2-to-16MHz
- External Oscillator: Crystal, RC, C, or Clock
- Real-Time Clock Mode using Timer 3 or PCA

SUPPLY VOLTAGE 2.7V to 3.6V

- Typical Operating Current: 10mA @ 25MHz
- Multiple Power Saving Sleep and Shutdown Modes

64-Pin TQFP (100-Pin Version Available)

Temperature Range: -40°C to $+85^{\circ}\text{C}$

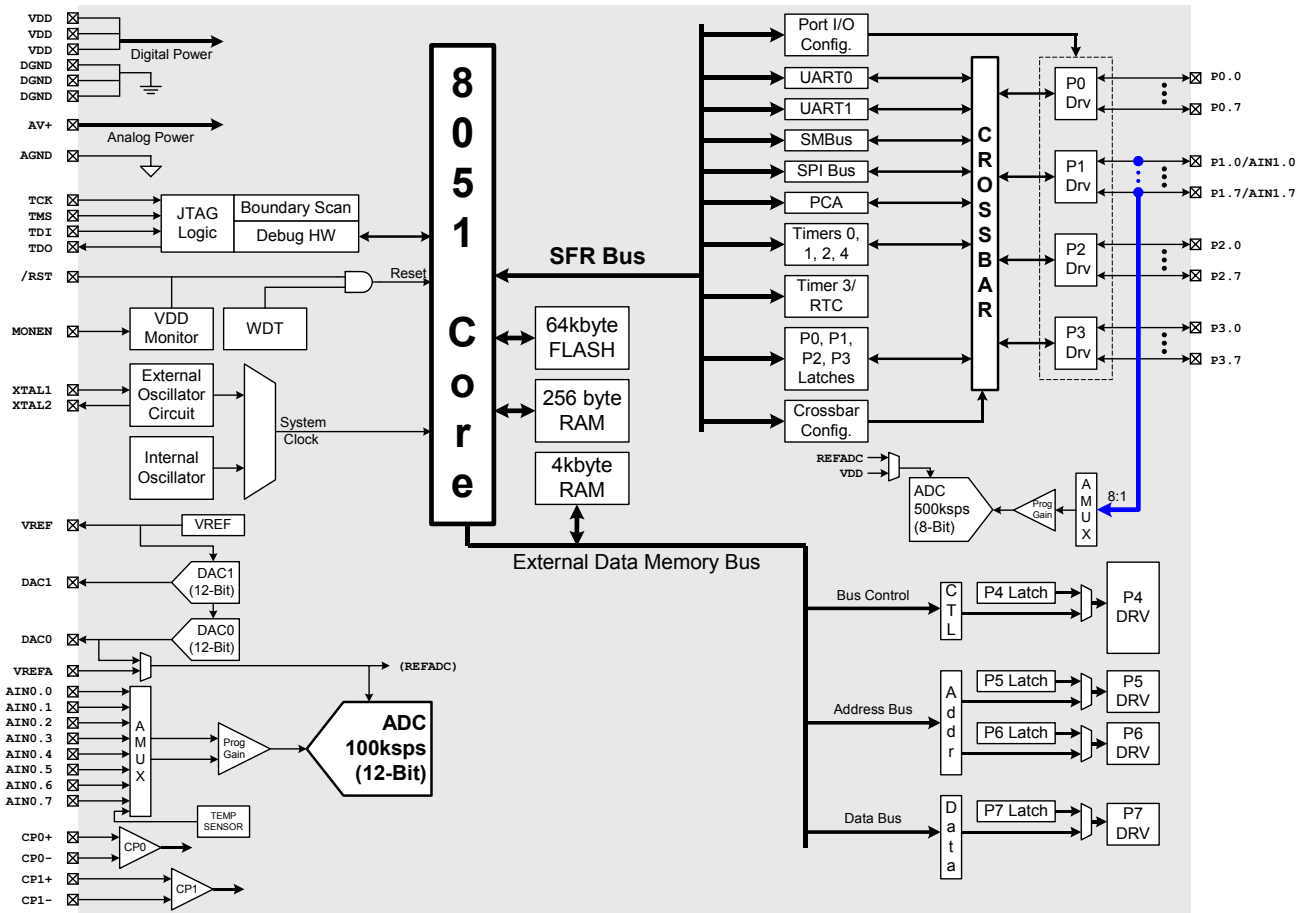

SELECTED ELECTRICAL SPECIFICATIONS TA = -40°C to +85°C unless otherwise specified.

| PARAMETER | CONDITIONS | MIN | TYP | MAX | UNITS |
|---|---|-----------|-----------------|------------|----------------|
| GLOBAL CHARACTERISTICS | | | | | |
| Digital Supply Voltage | | 2.7 | | 3.6 | V |
| Digital Supply Current with CPU active (VDD=2.7V) | Clock=25MHz Clock=1MHz Clock=32kHz; VDD Monitor Disabled | | 10 0.8 20 | | mA mA µA |
| Digital Supply Current (shutdown) | Oscillator not running; VDD Monitor Enabled Oscillator not running; VDD Monitor Disabled | | 10 0.1 | | µA µA |
| Digital Supply RAM Data Retention Voltage | | | 1.5 | | V |
| CPU & DIGITAL I/O PORTS | | | | | |
| Clock Frequency Range | | DC | | 25 | MHz |
| Port Output High Voltage | I _{OH} = -3mA, Port I/O push-pull | VDD - 0.7 | | | V |
| Port Output Low Voltage | I _{OL} = 8.5mA | | | 0.6 | V |
| Input High Voltage | | 0.7 x VDD | | | V |
| Input Low Voltage | | | | 0.3 x VDD | V |
| A/D CONVERTER | | | | | |
| Resolution | | | 12 | | bits |
| Integral Nonlinearity | | | | ± 1 | LSB |
| Differential Nonlinearity | Guaranteed Monotonic | | | ± 1 | LSB |
| Signal-to-Noise Plus Distortion | | 66 | | | dB |
| Throughput Rate | | | | 100 | ksp/s |
| Input Voltage Range | | 0 | | VREF | V |
| COMPARATORS | | | | | |
| Response Time | CP+ - CP- = 100mV | | 4 | | µs |
| Input Voltage Range | | -0.25 | | VDD + 0.25 | V |
| Input Bias Current | | -5 | 0.001 | +5 | nA |
| Input Offset Voltage | | -10 | | +10 | mV |

